

**MODEL MK-MANTA II  
CORE DRILL  
OWNER'S MANUAL  
PARTS LIST &  
OPERATING  
INSTRUCTIONS**



**CAUTION**  
**READ SAFETY  
AND GENERAL  
INSTRUCTIONS  
CAREFULLY  
BEFORE USING  
SAW FOR THE  
FIRST TIME.**

**PLEASE RECORD THE SERIAL NUMBER OF  
YOUR DRILL IN THIS BLOCK.**

**SERIAL NUMBER**

**FOR YOUR ONE (1) YEAR WARRANTY TO  
BE EFFECTIVE, COMPLETE THE WARRANTY  
CARD (INCLUDE THE SERIAL NUMBER) AND  
MAIL IT IN AS SOON AS POSSIBLE.**

Manual Part No. 161116  
Revision 03/05

**MK-MANTA II**

## MK Diamond's Manta I Core Drill - Operators Manual

<u>General Safety Instructions</u>	2
Safety Messages and Symbols	3
Hazard Symbols	3
Damage Prevention Messages	3
Safety Labels	3
<u>Drill Features</u>	
Motor	4
Carriage, Column and Base	4
Vacuum Base and Pump	4
Water System	4
<u>Unpacking</u>	5
<u>Assembly</u>	
Main Assembly	6
Feed Handle and Meter Box	6
Vacuum Base Gasket	6
Final Assembly	6
<u>Drilling Operations</u>	
Electrical Requirements	7
Grounding	7
Extension Cords	7
Securing the Rig	8
Drilling Speeds	9
Drilling Pressure and the Ammeter	9
Water Supply	9
Carriage Rigidity	10
Shear Pin and Clutch Protection	10
Mounting Bits	10
Drilling Procedure	10
Deep Drilling	12
<u>Maintenance</u>	
Cleaning	12
Vacuum Base Gasket	12
<u>Trouble Shooting</u>	13
<u>Warranty Information</u>	14
<u>Exploded View &amp; Parts List</u>	
Exploded View	15-18
Parts List	19-21
<u>MK Diamond Authorized Service Center</u>	Back Cover
<u>How to Order Repair Parts</u>	Back Cover
<u>Returned Merchandise Policy</u>	Back Cover

# General Safety Instructions for the MK-MANTA II Core Drill

## For your Safety!

These safety precautions should be followed at all times. Failure to follow these safety precautions could result in injury to yourself and others. Safety is a combination of operator common sense and alertness at all times when this drill rig is being used.



For your own safety and protection, do not attempt to operate the drill until it is completely assembled and installed according to the instructions, and until you read and understand all safety and operating instructions.

Take time to read and understand fully the owners manual and all safety labels attached to the core drill.



Use safety equipment. Everyone in the work area should wear safety goggles or glasses with side shields complying with current safety standards. Wear hearing protection during extended use and a dust mask for dusty operations. Hard hats, face shields, safety shoes, etc. should be used when specified or necessary.

Use the right tool. Do not use a tool or attachment to do a job for which it is not recommended. Do not alter the tool.

Keep your work area clean and safe to avoid accidents. Maintain a safe zone and keep all visitors at a safe distance from the work area.

Always insure that the switch is off before plugging unit into electrical power.

Never leave the drill running unattended. Turn power off.

Do not over reach, maintain control. Keep proper footing and balance at all times. Maintain a firm grip. Use extra care when using the tool on ladders, roofs, scaffolds, etc.

Maintain all tools with care for the safest and best performance.

Should any part of this drill become missing or damaged, or any component fail to perform properly, shut off the drill and unplug the power source. Replace the missing, damaged, and/or failed part before resuming operations.

Always keep alert. Do not allow familiarity (gained from frequent use) to cause a careless mistake. Always remember that a careless fraction of a second is sufficient to inflict serious injury.

Think Safety The operation of any power tool can result in foreign objects being thrown into the eyes causing severe damage. Use safety goggles to comply with ANSI Z87.1.

FORESIGHT IS BETTER THAN NO SIGHT

## Safety Messages

A safety message informs you about potential hazards that could hurt you or others. Each safety message is preceded by one of the three words: Danger, Warning, or Caution.

### **DANGER**

You **WILL** be **KILLED** or **SERIOUSLY** injured if you don't follow instructions.

### **WARNING**

You **CAN** be **KILLED** or **SERIOUSLY** injured if you don't follow instructions.

### **CAUTION**

You **CAN** be injured if you don't follow instructions.

## Hazard Symbols

Additional information as to the nature of the hazard is provided by the following hazard symbols, which appear throughout the manual in conjunction with safety messages.



### **Electrical Shock!**

Never touch electrical wires or components while the drill is running. They can be sources of electrical shock which could cause severe injury or burns.



### **Accidental Starts!**

Before performing any maintenance or service on this equipment, always turn the switch off and unplug the drill from the power source to prevent accidental starting.



### **Rotating Parts!**

Keep hands, feet, hair, and clothing away from all moving parts to prevent injury.

## Damage Prevention Messages

Other important messages that are designed to help prevent damage to your MK Diamond Manta Core Drill, other property, or the environment, are preceded by the word notice.

**Notice:** Your MK-MANTA II Core Drill or other property could be damaged if you don't follow instructions.

## Safety Labels

Safety labels contain important safety information. Please read them carefully. These labels are considered a permanent part of your drill. If a label comes off or becomes hard to read, contact MK Diamond or your dealer for replacement.



# Manta I Core Drilling Machine

## Drill Features

The MK-MANTA II Core Drill is a powerful all-purpose drilling rig that is designed to drill holes, up to 12 inches in diameter (14 inches with the 2 inch spacer), in all types of concrete slabs, floors, walls, and ceilings. The Manta is designed for easy anchoring using masonry anchors. A secondary vacuum base is provided to facilitate quick and easy anchoring to smooth floor surfaces.

## Motor

The Manta is designed for use with a variety of motors. All motors are powerful two or three speed units that provide the correct cutting speed over a range of diamond drill sizes. Some models utilize a shear-pin system for motor protection, while some others utilize a slip-clutch. See the Drilling Speeds section of this manual.

## Carraige, Column and Base

The carriage, column and base assembly of the Manta II Core Drill is the strong, sturdy drilling platform that provides the rigidity needed to quickly drill accurately placed, straight, smooth holes in all types of concrete. The Manta's base is slotted to provide easy anchoring of the drill, in a variety of drilling situations, with a single masonry anchor. The slot also allows more than one hole to be drilled from a single anchor location. The base contains four leveling screws to insure accurate hole alignment even on uneven concrete surfaces. The base also has a cast in handle and a set of wheels to provide easy transport. The carriage travel is controlled by a strong rack and pinion gear-system, that can be locked at any point on the column. The sliding handle allows the operator to easily control the drilling pressure and speed. At the top of the column is a strong jack-screw that allows for additional bracing to overhead or opposite surfaces.

## Vacuum Base and Pump

The vacuum base and pump provide quick and reliable mounting to smooth concrete slab and floor surfaces. The powerful vacuum pump provides 25 PSI of holding power which equates to over 1800 pounds of force, holding the Manta securely, for safe, accurate drilling. The pump has a quick disconnect connector on the hose, as well as an ergonomic handle, to provide ease of transport. The vacuum base also features leveling screws, a cast-in handle and six inch (6") wheels.

## Water System

The water system for the Manta is a simple hose hook-up and shut-off valve that provides water under pressure to the diamond drill bit. The water travels to the center of the bit through the water swivel and spindle to insure that water is supplied to the cutting end of the bit, even in deep drilling operations.

## Unpacking

Carefully cut through the carton approximately 6 inches from the bottom using a box cutter or other safety knife, and lift away the top portion of the box. Remove the Accessory Pack, Vacuum Pump and Manta Core Drill. Open the accessory pack and check each item with the contents list and illustration below, making certain that all items are accounted for and in good condition before discarding any packing material. If there are any missing or damaged parts, call our toll free number 1-(800)-421-5830 for instructions before proceeding with the assembly.

### CONTENTS

Contents of the carton: Manta (including column, carriage, base and motor), Vacuum Pump and Accessory Pack.

In the Accessory Pack you will find: Control box, leveling screws (4), feed handle (1) and knobs (2), vacuum base gasket, wrench, Manta manual, Manta warranty card, motor manual and motor warranty card.



Manta and Vacuum Pump

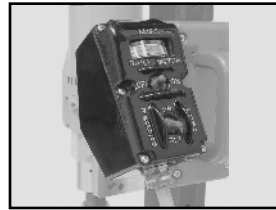

Control Box



Vacuum Pump



Leveling Screws

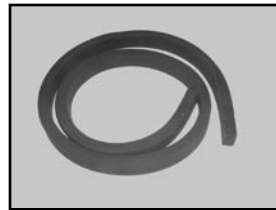

Base Gasket

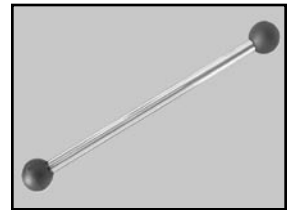

Feed Handle and Knobs

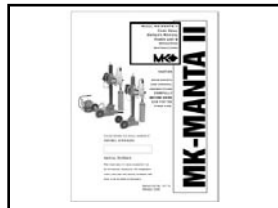

Manta Manual



Warranty Card

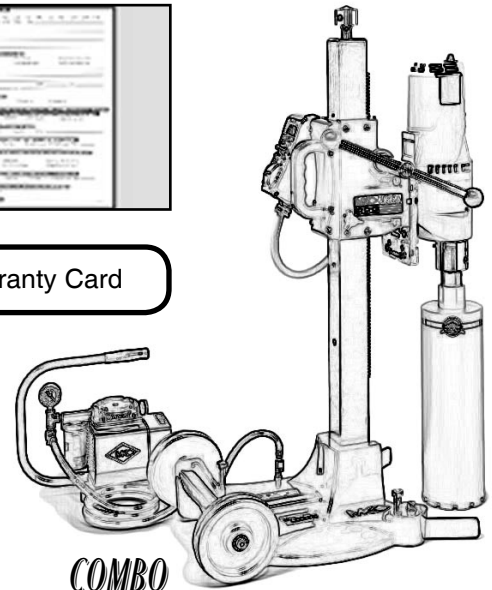
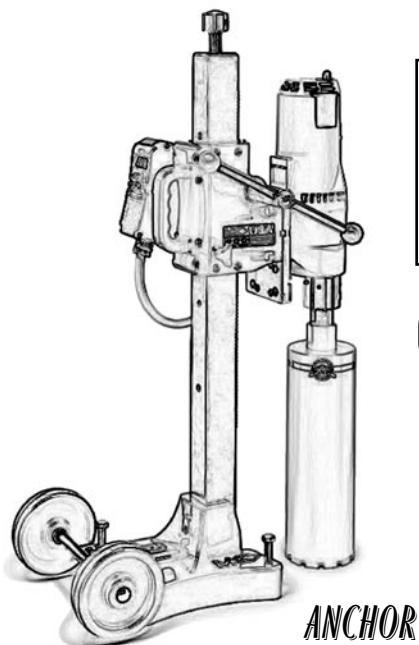

## Assembly

### **WARNING**

For your own safety and protection, do not attempt to operate this drill until it is completely assembled and installed according to these instructions, and until you understand the machines capabilities and the potential hazards associated with it.

## Main Assembly

**Step 1** The Manta I is shipped with the carriage mounted backwards on the column. Loosen the knob, remove the carriage and orient it with the motor facing forward.



### **CAUTION**

Be sure to hold the Manta when removing the vacuum base to prevent tipping forward.

To set the Manta so that it will stand up, loosen the carriage lock knob (be sure to hold the carriage) and move the carriage down to a position where the end of the motor spindle just touches the ground.

**Step 2** Install the leveling screws (4) by screwing them into base.

## Feed Handle and Meter Box

**Step 3** Install the feed handles (1) and knobs (2) by screwing one knob onto the end of the handle, then slip thru hub and attach other knob.

## Vacuum Base Gasket

Turn the vacuum base over. Press the gasket into the groove in the underside of the base. The gasket is cut, at the factory, to the correct length, so that the two ends will butt together once the gasket is installed.

## Final Assembly

**Step 4** Assemble the two pieces of the water valve, and install the valve, into the water swivel, on the motor, just above the spindle (see motor literature).

Plug the cord from the motor into the upper outlet on the meter box (the one opposite the motor on-off switch. The other outlet on the meter box is for the vacuum pump.

# Drilling Operations

## Electrical Requirements

### Grounding

**NEMA L5-20** 125 V, 20 Amp  
Locking Plug and receptacle

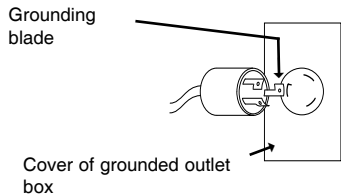

**NEMA L5-30** 125 V, 30 Amp  
Locking Plug and receptacle

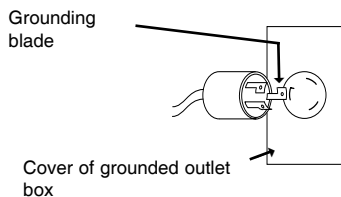

The MK-MANTA II Core Drill rig has been equipped with either the Milwaukee 20 Amp/115V 2 speed motor or the Black & Decker 18 Amp/115V 2 speed motor. The drill should be used on an electrical circuit, separate from other loads, and protected by a 30 amp circuit breaker.

The MK-MANTA II has been provided with a 20 Amp plug (NEMA 15-20) or a 30 Amp (NEMA 15-30) locking plug depending on the model.

The MK Manta is marked "Grounding Required" and has a three wire cord and three prong grounding plug. The plug must be connected to a properly grounded outlet (see figure below). If the tool should electrically malfunction or break down, grounding provides a low resistance path to carry electricity away from the user, reducing the risk of electrical shock.

The grounding prong in the plug is connected through the green wire inside the cord to the grounding system in the tool. The green wire in the cord must be the only wire connected to the tool's grounding systems and must never be attached to an electrically live terminal.

Your tool must be plugged into an appropriate outlet, properly installed and grounded in accordance with all codes and ordinances. The plug and outlet should look like those in the figure to the left.

### **! WARNING**

Improperly connecting the grounding wire can result in the risk of electric shock. Check with a qualified electrician if you are in doubt as to whether the outlet is properly grounded. Do not modify the plug provided with the tool. Never remove the grounding prong from the plug. Do not use the tool if the cord or plug is damaged. If damaged, have it repaired by an authorized service facility before use. If the plug will not fit the outlet, have a proper outlet installed by a qualified electrician. The use of a circuit protected by a ground fault interrupter (GFI) is highly recommended.

Use extension cords of the proper cable size, referring to the following chart.

### Extension Cords

Cord Length	25 feet	50 feet	75 feet
Wire Size (AWG)	#10	#8	#6



### **! WARNING**

Never use an extension cord smaller than shown in the chart. Be sure your extension cord is properly wired and in good electrical condition. Always replace a damaged extension cord or have it repaired by a qualified electrician before using it.

Protect your extension cords from sharp objects, excessive heat and damp or wet areas.

**Notice:** Using an extension cord with inadequately sized wire causes a serious drop in voltage, resulting in loss of power and possible tool damage.

## Securing the Rig

### Recommended Methods

A. Use a concrete anchor. Use either a 1/2 or 5/8 concrete anchor to secure the base to the work surface. Always be sure to level the rig before tightening the anchor. Using a concrete anchor, insert a bolt through the slot located on the base and tighten the bolt firmly in the anchor.

#### **WARNING**

It is essential to always secure the rig to the work surface to help prevent personal injury and also to protect the rig. An unsecured rig could rotate during drilling and possibly cause injury. It could also cause the bit to chatter against the work surface or bind in a hole, which can fracture the diamond segments.

B. Vacuum base. The MK-MANTA II Core Drill Rig is equipped with a vacuum base. This base is designed to provide approximately 1800 pounds of total holding power. In order to provide the most rigidity to your core rig the unit should be used on a relatively smooth surface such as concrete. (If the surface is too porous or rough the vacuum mount may not hold securely.)

1. Turn the vacuum pump on and step on the vacuum base until a vacuum is created and the base adheres to the work surface.
2. Level the rig using the leveling bolts. Use a minimum amount of adjustment to the leveling bolts to avoid breaking the vacuum seal.

The vacuum gauge should read approximately 25 pounds per square inch (PSI) of pressure. If the gauge reads 20 PSI or less, check the work surface for conditions which may interfere with adequate suction such as cracks, dirt or debris on a porous surface.



#### **WARNING**

Do not drill if the gauge reads less than 20 PSI. Do not use vacuum base on cracked, uneven, porous or vertical surfaces.

C. Additional support. For added rigidity, you may use a telescoping extension assembly in conjunction with a concrete anchor or vacuum base. To use a telescoping assembly, first level the rig with the leveling screws. Secure the rig with an anchor or the vacuum base. Place the top flange of the extension against a ceiling or wall and place the other end on the jack screw of the column. The assembly is adjustable up to 14 feet. Use the jack screw to tighten the assembly and to make small adjustments.

The MK-MANTA II features two or three speed motors by various manufacturers. Specifications for the different motors are listed in the following table.

## Drilling Speeds

Manufacturer	Model #	AMP	Volts	Speed(RPM)	Suggested Dia. in Medium Aggregate
Eibenstock	EBM 300/3 P	20	120	Low – 270 Medium – 700 High – 1250	Low – 4” Medium – 2”-6” High – 3/4”-4”
Milwaukee	4004	20	120	Low – 300 High – 600	Low – 4” High – 14”
Milwaukee	4090	15	120	Low – 375 High – 750	Low – 5”-8” High – 2 1/2”-5”
Milwaukee	4094	20	120	Low – 450 High – 900	Low – 6”-10” High – 2”-6”
Milwaukee	4096	20	120	Low – 450 High – 900	Low – 6”-10” High – 2”-6”
Milwaukee	4097-20	15	120	Low – 500 High – 1000	Low – 1 1/4” High – 5”

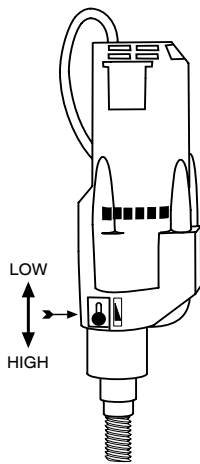

The MK-MANTA II will operate in either a high or low gear speed. This speed combined with applied pressure provides the cutting action for the core bit. Speed selection and pressure are determined by hardness of material, aggregate size and grade of diamond core bit. Generally, harder material and larger aggregates require more speed and pressure. Use low speed for large diameter bits and high speed for small diameter bits. Changing of the speeds is accomplished by using the speed shift lever built into the gear case.

**Notice:** Change the gears only when the motor is off.

All building materials and work surfaces are composed of aggregate of various size. Aggregates are materials such as gravel or crushed stone. The size of the grains and the hardness of the material affects the speed of drilling. Most building materials contain some type of steel reinforcements. All MK bits are designed to cut through these types of reinforcing steel. However, bits should never be used for drilling solid steel plates. Proper selection of the diamond core bit should be based on material to be drilled and performance requirements.

## Drilling Pressure and the Ammeter

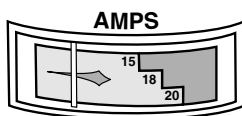

Steady, even pressure assures accurate holes and longer bit life. Always maintain consistent pressure so that the bit is constantly cutting.

**Notice:** Too much pressure will damage the bit and motor. Too little pressure will glaze over the diamonds, reducing cutting efficiency and prematurely wearing the bit. The ammeter is the gauge on the Control Box. It provides pressure feedback information during drilling, allowing the operator to help prevent motor overload and premature bit wear. The green area is the operating range, and the red area is the overload range. Generally, the operator should keep the ammeter needle in the upper area of the operating range for large diameter bits, and in the lower green area for small diameter bits. If the bit contacts steel reinforcing rods, the needle on the ammeter may jump slightly showing a heavier load. If this occurs, do not decrease pressure or you may damage the diamonds. The Manta may be operated with the ammeter needle into the red area for the short period of time that it takes to cut through a steel rod.

## Water Supply

An adequate supply of clean water is necessary for drilling. Connect the water supply hose to the hose fitting on the output of core drill motor. Take precautions that the water supply will not be interrupted during the drilling operations.

**Notice:** If a bit is run dry it can be ruined in a few seconds.

## Carriage Rigidity

It is essential that the carriage fits snugly on the column to prevent the motor or bit from wobbling during drilling. Through normal use the carriage may loosen from the column and begin to wobble. Before drilling, always make sure the carriage is rigid by trying to wiggle it with your hand. If the carriage is secure it should not move. If it does move, tighten the adjustment screws for the nylon gibs that secure the carriage to the column. Tighten only enough to remove the play. Do not over tighten.

## Shear Pin and Clutch Protection

The MK-MANTA II Core Drill uses either a shear pin or a friction clutch to protect the gear and motor against overload. The shear pin drives the outer portion of the drive spindle. If the motor should overload the pin will shear. Extra shear pins are supplied or can be ordered from MK Diamond's Customer Service. Another model features a friction clutch rather than a shear pin to protect the motor and gears. If the motor overloads the clutch will begin to slip and the bit will stop rotating. The clutch is factory-set and does not require adjustments. However, under normal use, the clutch may start to slip at low torque. If this happens, refer to the motors Owner's Manual.

Bits with permanently attached adapters simply screw directly onto the threads of the drill spindle. Ensure that the end of the bit butts up squarely against the shoulder on the spindle.

## Mounting Bits

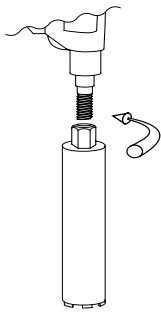

The MK-MANTA II has a 1 1/4"-7 thread. For bits with other threads, use a shaft coupling. After a bit has been mounted, turn the power on and check that there is a minimum of run-out or wobble.

### **⚠ WARNING**

To reduce the risk of injury, always unplug tool before attaching or removing accessories. Only use specifically recommended accessories. Others may be hazardous.

### **⚠ WARNING**

When drilling through concrete floors, the core will generally drop from the diamond bit. Caution should be provided for people and property below the drilling area.

## Drilling Procedure

1. Ensure that you have read and fully understand the complete operation of the MK-MANTA II you have purchased prior to commencing drilling operations.
2. Select and install a diamond core bit appropriate for the job. Note: Grease the bit threads to help prevent the bit from seizing on the spindle due to rust.
3. Select either high or low gear speed according to the chart in the Drilling Speeds section of this manual. (Do not shift speed when motor is on.)
4. Connect water hose to water swivel.
5. Secure the rig as described in the Securing the rig section of this manual.



## **! WARNING**

If using the vacuum base, do not continue operations unless the vacuum gauge reads more than 20 inches of mercury. Normally, the gauge will read 23 inches or more.

6. Turn the motor switch on the control box on. Turn the water on so that an adequate flow of water is supplied through the water swivel, to the bit. Hold the handle and slightly loosen the carriage lock knob. Slowly rotate the handle to lower the bit into the work piece - apply steady even pressure.

**Note:** To prevent the bit from wandering, always use a light load to start the hole and wait for the diamond tip of the bit to penetrate the work surface before increasing the load.

7. Use consistent pressure so that the bit cuts consistently. Insufficient pressure will cause the diamond core bit to glaze over. Too much pressure will overload the motor and crush the diamonds. Use the ammeter on the control box as a guide for proper pressure.

## **! CAUTION**

If the rig shifts during drilling, stop the motor, reposition the rig, and resume drilling.

8. Monitor the water flow. If the water flow is adequate, the water leaving the cut should be slightly sludgy. When cutting metal rebar, the water should have a gray metal coloring.

**Notice:** When drilling into prestressed concrete the bit may cut into the hardened steel cable under tension. As the bit cuts through each strand, the tension in the cable is released. The diamond segments on the bit crown can be damaged by the loose wires. The best prevention for bit damage is to use a core bit designed especially for drilling in prestressed concrete.

9. When the cut is complete, keep the drill motor on and rotate the handle to bring the bit up out of the hole. The bit may become stuck if the motor is turned off before the bit is completely clear of the hole. Once the bit is clear of the hole, tighten the carriage lock knob, turn off the motor and the water supply.

**Note:** Normally the core will drop out of the bit, and remain in the hole. However, in cases where the core sticks in the bit, it is sometimes necessary to push the core up and down with the water running to allow the core to drop out. Sometimes very light tapping on the barrel of the bit with a piece of wood will loosen the core.

## **! CAUTION**

Perform this action only with the motor turned off and the unit unplugged to prevent accidental starting and injury. Exercise extreme caution in hand placement when removing a stuck core, as it can be heavy and inflict injury.

## Deep Drilling

When drilling holes that are longer than the core bit, follow the steps below.

1. Begin drilling the hole as usual. When you have drilled to the length of the bit, retract the bit from the hole and turn off the motor and water as usual.
2. Break off the core by driving a chisel or slender wedge into the circular kerf. Remove the core using core tongs, bent music wire or anchor bolts.
3. After removing the core, insert the bit carefully into the hole, attach a bit extension to the bit and core drill rig, then continue drilling as usual.

## Maintenance

Periodic maintenance, including cleaning, lubrication and inspection for wear and damage are routine servicing procedures. Following the procedures as outlined can prevent serious damage or malfunctioning of the machine, and aid in preserving the useful life of core drill bits.



### **CAUTION**

Before performing any maintenance to the MK-MANTA II, always unplug the unit from the electrical power source. Be sure the On-Off switches are in the Off position, after servicing, and before plugging the unit back in.

## Cleaning

Clean the machine after use, being careful to remove dust and slurry from the motor, vents, carriage and column. Keep tool handles clean, dry and free of oil and grease. Use only mild soap and a damp cloth to clean this tool since certain cleaning agents and solvents are harmful to plastics and other insulated parts.



### **WARNING**

Never use flammable or combustible solvents around tools.

## Vacuum Base Gasket

Through normal use, the rubber gasket on the underside of the vacuum base can become worn, requiring replacement. Periodically check the gasket for wear. If replacement is required, clean the groove in the base before installing a new gasket.

## Troubleshooting

When trouble occurs, be sure to check the simple causes which, at first, may seem too obvious to be considered. Refer to the table below for problems and their possible causes.

PROBLEM	WHAT TO DO?	INDICATION	CAUSE	SOLUTION/ RECOMMENDATIONS	
Low Penetration Rate Under Prevailing Drilling Parameters	1. Check fluid return.	Fluid not muddy. Evidence of steel cuttings	Drilling in steel reinforcement	Adjust drilling parameters to recommendations for reinforcement	
	2. Check motor speed range		Speed not correct for the bit size used	See recommended speeds	
	3. Check wear picture of bit face		Bit worn out.		Replace with new bit
			Diamond without exposure. (flush with matrix)	Insufficient bit load	Increase bit load
				Rotated with high RPM on reinforcement	Reduce RPM, or resharpen bit
				Loose material at bottom of hole	Break core, clean bottom of hole or reduce RPM and drill with increased bit load
			Face of bit plugged with cuttings	Not enough fluid pumped. Cuttings burnt to matrix. Diamonds prevented from cutting	Clean bit face by sharpening methods such as drilling dry at low RPM in a concrete block 3/8" deep max. Increase water flow rate
			Face of bit covered with steel. Steel cuttings stick to bit face.	Steel cuttings stick to bit face. Diamonds prevented from cutting	Clean bit face by drilling in concrete block. Reduce RPM
			Wear picture of polished diamonds	Bit load too low	Increase bit load
	Bit speed too high	Use lower speed; increase bit load			
Heavy Wear at Steel Tube		Deep grooves.	Worn or open guide ways on cradle. Borehole is getting undulated	Adjust guidance on carriage	
			Protruding steel. Spindle is offset. Bit out of true	Adjust guidance on carriage Nicks or dirt on mounting faces	
		Heavy Wear.	Bit is deformed.	Replace bit.	
			Poor cleaning of abrasive cuttings.	Improve flushing.	
			Crown clearance worn out.	Replace bit	
		No return of fluid	Check where fluid is leaking.		

PROBLEM	WHAT TO DO?	INDICATION	SOLUTION/ RECOMMENDATIONS
Bit Stuck	1. Try to raise bit, if impossible:  2. Stop rotation	Loose material (cut steel or aggregates) is blocking between core and bit or between borehole and bit.	Step 1: Apply wrench and rotate bit in both directions while bit is under tension. If not successful:  Step 2: Try to over drill a hole slightly larger than the stuck bit.
		Drill moved during drilling (poor fastening).	Disconnect bit and remove, break core. Start over with improved fastening of machine.
		Bit deviates, guide ways on cradle have too much clearance.	Disconnect machine, adjust guidance.
		No clearance between tube I.D. or O.D. and crown I.D. or O.D.	Replace bit.
Shear Pin Fail	1. Stop rotation  2. Raise bit	Drill impacted to stall at lower speeds.	Use recommended speed for the bit diameter used. Raise bit when it begins to load down. Feed bit slowly when chattering begins.

## Warranty Information

If within one (1) year from the date of purchase, this MK Diamond drill fails due to a defect in material or workmanship, MK will repair it, free of charge, by returning the unit to the dealer where it was purchased. This warranty DOES NOT cover normal wear or damage resulting from operator abuse. In no event shall MK Diamond Products, Inc. be liable for consequential damages arising out of the failure of any product if operating improperly. Selected components such as motors/engines are excluded from this warranty and are subject to the manufacturer's warranty. Each manufacturer carries its own warranty conditions which are listed on the literature accompanying the motor/engine at the time of purchase. MK Diamond Products may act as a warranty station for the motor/engine repairs based on individual agreement with the manufacturer. This warranty is in lieu of all other warranties expressed or implied.

# MANTA II COMBO EXPLODED VIEW AND PARTS LIST

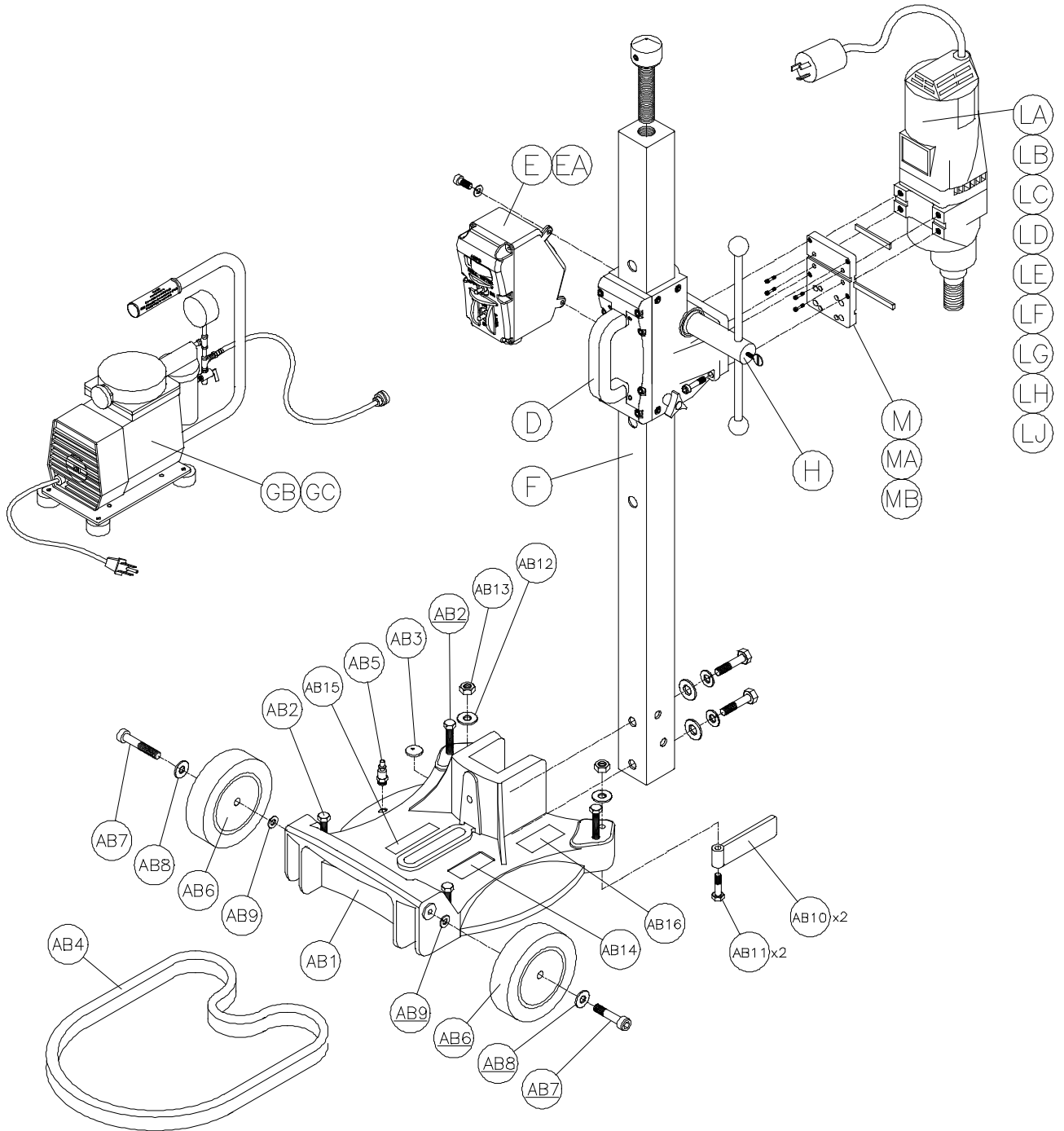

MANTA II COMBO  
W/ 2 1/2 COLUMN

**EXPLODED VIEW**

# MANTA II EXPLODED VIEW

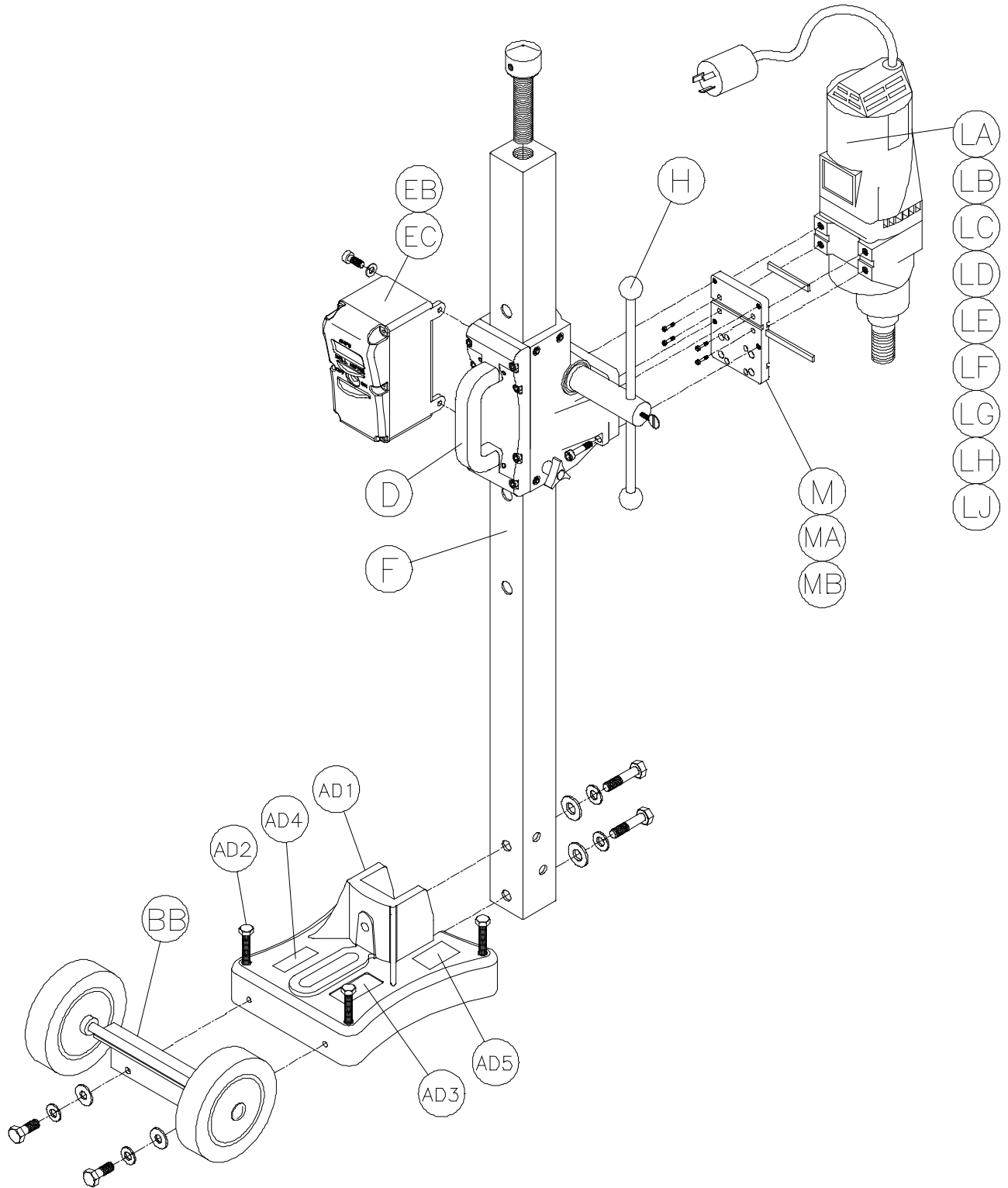

## MANTA II ANCHOR

# MANTA II EXPLODED VIEW (cont...)

ASSEMBLY "D"

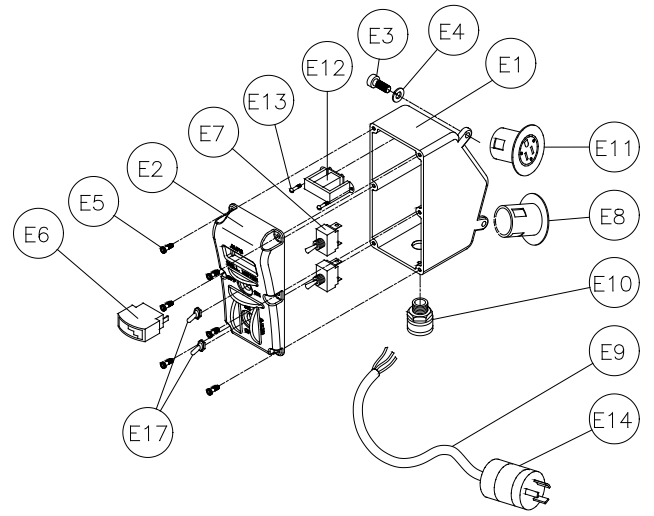
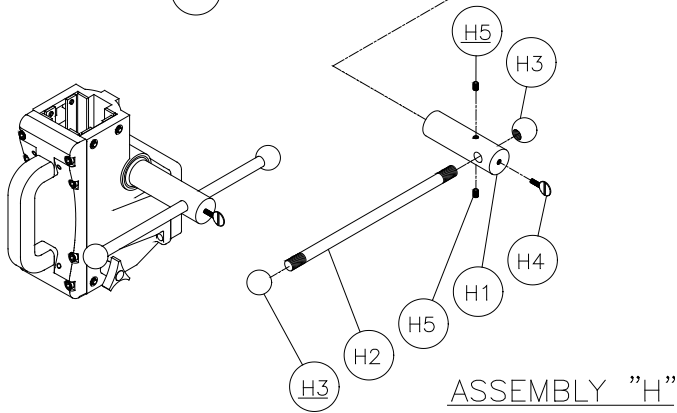
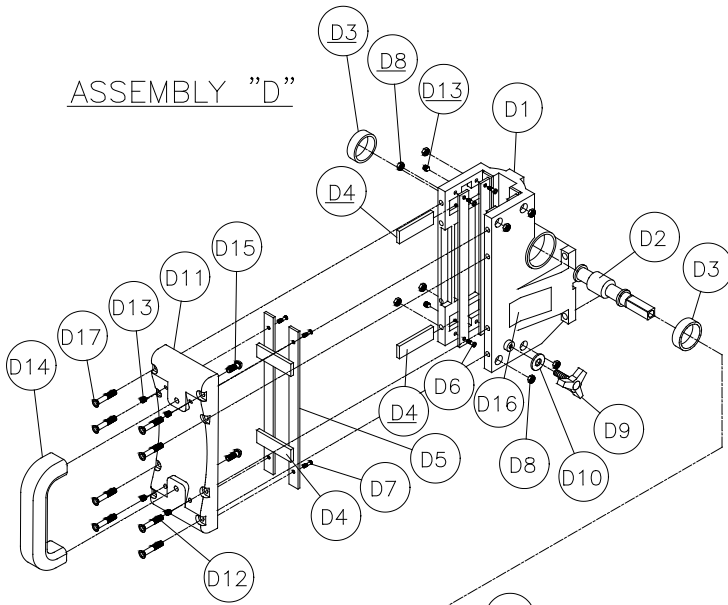

ASSEMBLY "E & EA"

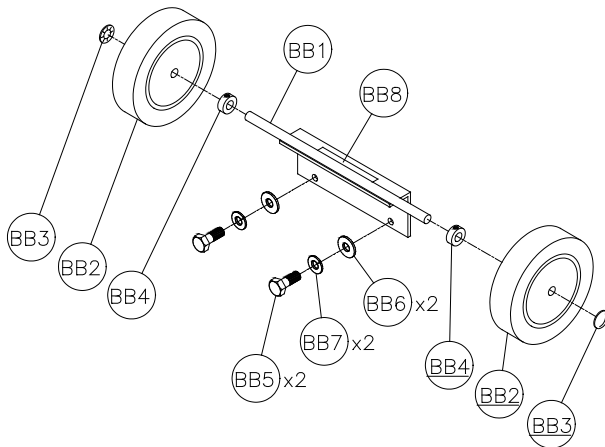

ASSEMBLY "BB"

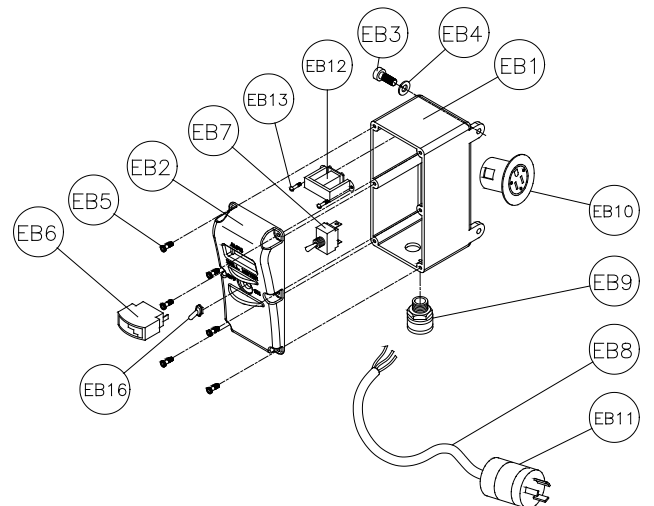

ASSEMBLY "EB & EC"

# MANTA II EXPLODED VIEW (cont...)

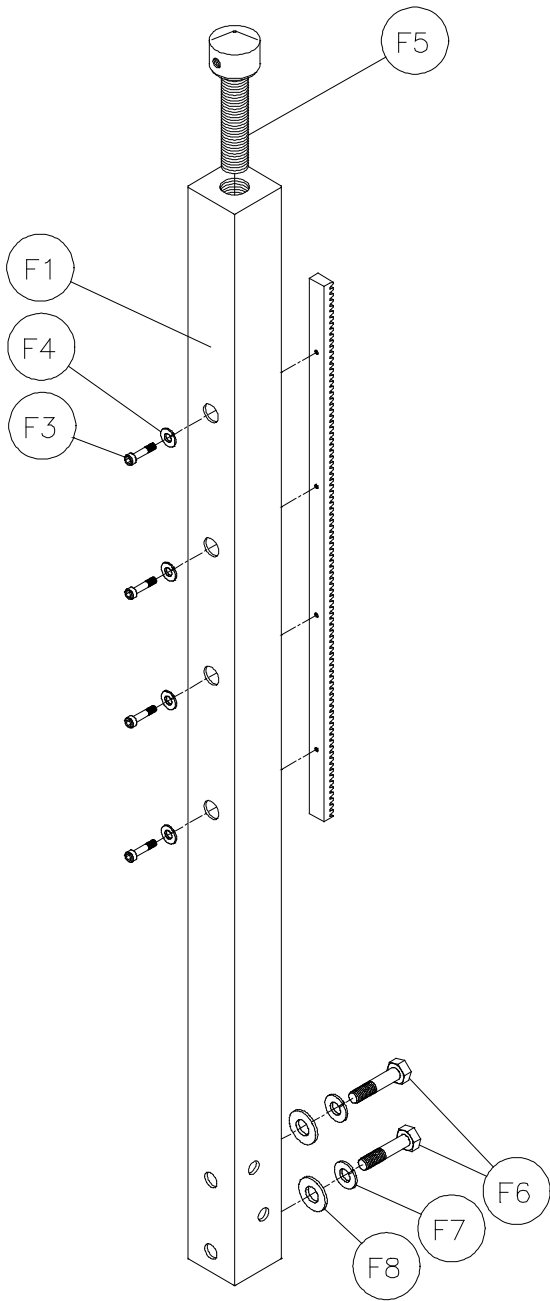

ASSEMBLY "F"

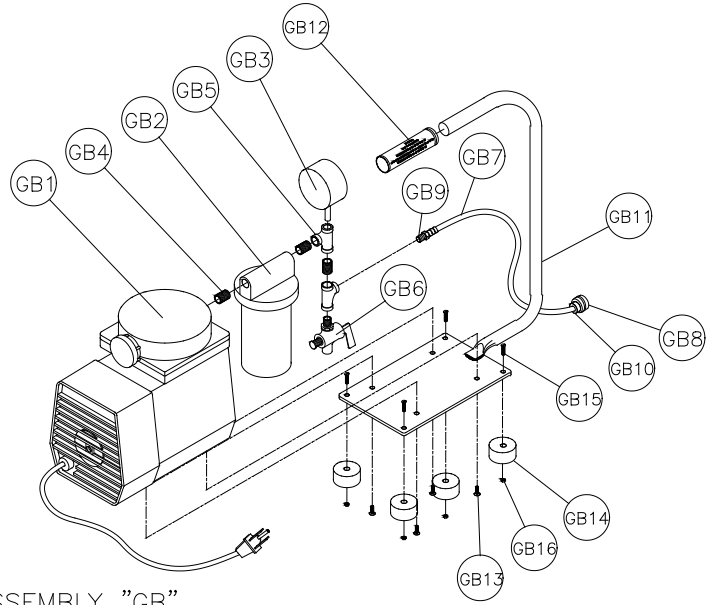

ASSEMBLY "GB"

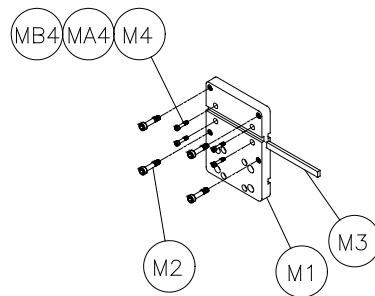
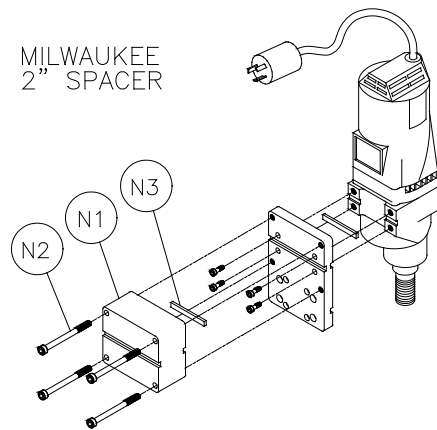

ASSEMBLY "M, MA & MB"

## MANTA II PARTS LIST

### PARTS LIST:

Item	Description	Qty	MK p/n
AB	Assembly, M2 Base, 2 ½ Combination	1	n/a
AB1	Base, M2	1	158114
AB2	Screw, ½-13 x 3 ½ Hex Hd. Cap, Full Thread	4	158284
AB3	Level, Circular Bubble	1	157429
AB4	Gasket, Neoprene	3.98'	154543
AB5	Fitting, ¼ MNPT x 3/8 Barb	1	154659
AB6	Wheel 6" x 1 ½ x ½ axle	2	157434
AB7	Screw, 1/2 x 1 3/4 Socket Head Shoulder	2	158390
AB8	Washer, ½ SAE Flat	2	150924
AB9	Washer, 5/16 Split Lock	2	151747
AB10	Foot, Base Support	2	158389
AB11	Screw, 3/8-16 x 2 ¼ Hex Head Cap	2	153529
AB12	Washer, 3/8 SAE Flat	2	150923
AB13	Nut, 3/8-16 Hex Nylok	2	152505
AB14	Label, Manta Serial Tag	1	157730
AB15	Label, Caution, Safety	1	155576
AB16	Label, MK, Adhesive	1	157914
AD	Assembly, M2 Base, Anchor	1	n/a
AD1	Base, M2 Anchor	1	158410
AD2	Screw, ½-13 x 3 ½ Hex Hd. Cap, Full Thread	4	158284
AD3	Label, Manta Serial Tag	1	157730
AD4	Label, Caution, Safety	1	155576
AD5	Label, MK, Adhesive	1	157914
BB	Assembly, Wheel Bracket, Anchor		N/a
BB1	Bracket, Wheel, Anchor	1	158457
BB2	Wheel 6" x 1 ½ x ½ axle	2	157434
BB3	Cap, Push ½" Stainless Steel	2	157435
BB4	Collar, ½ I.D. x 1" O.D. x 7/16	2	157518
BB5	Screw, 5/16 x 1 Hex Hd. Cap	2	151743
BB6	Washer, 5/16 SAE Flat	2	151754
BB7	Washer, 5/16 Split Lock	2	151747
BB8	Label, Manta 1-1/4 x 5 1/8	1	155388
D	Assembly, Carriage 2 ½"	1	n/a
D1	Body, Carriage	1	155757
D2	Shaft, Gear, Short	1	158348
D3	Bearing	2	137711
D4	Plate, Adjustment	3	157317
D5	Slide, Carriage	8	157318
D6	Screw, 6-32 x 1/2 Flat Head Phillips Machine	8	154448
D7	Screw, 6-32 x 3/8 Flat Head Phillips Machine	8	157521
D8	Nut, 6-32 Nylok Hex	8	157519
D9	Knob, Davies ¼-20 x ¾	1	151681
D10	Washer, ¼ SAE Flat	1	151915
D11	Back, Carriage	1	157438
D12	Screw, 1/4-20 X 1 Socket Head Cap	4	151049
D13	Screw, ¼-20 x 5/16 Socket Head Set	6	154226
D14	Handle, Carriage	1	157440
D15	Screw, 1/4-20 X ¾ Pan Head Phillips	2	157523
D16	Label, MK USA	2	154334
D17	Screw, 1/4-20 X 1 ¼ Socket Head Cap	4	159336
E	Assembly, Control Box, Fixed, Dual Switch 120V	1	158428
E1	Box, Control, Fixed	1	158274
E2	Cover, Control Box, Fixed, Dual Switch	1	158276

## MANTA II PARTS LIST (cont...)

E3	Screw, ¼-20 x ¾ Socket Head Cap	2	152587
E4	Washer, ¼ Split Lock	2	152591
E5	Screw, 10-24 x 5/8 Self Tapping (phillips)	6	153681
E6	Ammeter 120V	1	154489
E7	Switch, 30A Toggle	2	154491
E8	Receptacle, Flanged 15A / 125V	1	154473
E9	Cord, Power SOWA 12/3 Yellow	3'	154494
E10	Connector, Cord ½ (Appleton CG-5050)	1	151307
E11	Receptacle, Flanged Twist-lock 20A / 125V	1	157375
E12	Transformer, Current	1	154490
E13	Screw, 6-32 x ½ Pan Head	2	153459
E14	Plug, Twist-lock, 125V / 20A	1	154556
E15	Wire Harness (not shown)	1	154715
E16	RTV Silicon Adhesive Sealant (Bulk)	. 25oz.	n/a
E17	Cover, Toggle Switch	2	154301
EB	Assembly, Control Box, Single Switch 120V	1	158430
EB1	Box, Control, Single Switch	1	158385
EB2	Cover, Control Box, Single Switch	1	158387
EB3	Screw, ¼-20 x ¾ Socket Head Cap	2	152587
EB4	Washer, ¼ Split Lock	2	152591
EB5	Screw, 10-24 x 5/8 Self Tapping	6	153681
EB6	Ammeter 120V	1	154489
EB7	Switch, 30A Toggle	1	154491
EB8	Cord, Power	3'	154494
EB9	Connector, Cord ½	1	151307
EB10	Receptacle, Flanged Twist-lock	1	157375
EB11	Plug, Twist-lock	1	154556
EB12	Transformer, Current	1	154490
EB13	Screw, 6-32 x ½ Pan Head	2	153459
EB14	Wire Harness (modified)	1	154715
EB15	RTV Silicon Adhesive Sealant (Bulk)	.25 oz.	n/a
EB16	Cover, Toggle Switch	1	154301
F1	Assembly, Column		n/a
F1	Manta, Core Drill Column (w/Gear Rack)	1	158425-2
F3	Screw, 10-32 X ½ Socket Hd. Cap	4	157525
F4	Washer, #10 Split Lock	4	153684
F5	Screw, M22 x 1.25 Jack	1	157445
F6	Screw, 1/2-13 X 3 ½ Hex Head Cap	2	154574
F7	Washer, 1/2 Split Lock	2	153524
F8	Washer, 1/2 SAE Flat	2	150924
GB	Assembly, Vacuum Pump w/ Handle 120V	1	154741
GB1	Pump, Vacuum 120v	1	154475
GB2	Filter, Water	1	154476
GB3	Gauge, Vacuum	1	154477
GB4	Nipple, 1/4 MNPT X Close	3	152598
GB5	Fitting, 1/4 FNPT X 1/4 FNPT X 1/4 FNPT Tee	2	154497
GB6	Valve, 1/4" Pettcock	1	154488
GB7	Hose, 3/8 I.D. Air	6'	154656
GB8	Coupler Body, 1/4 FNPT	1	154617
GB9	Fitting, 1/4 MNPT X 3/8 BARB	2	154659
GB10	Ferrell, Crimp	2	154660
GB11	Base, Vacuum Pump	1	154495
GB12	Handgrip, 3/4 X 4 9/16 Black	1	139949
GB13	Screw, 10-32 X 1/2 Phillips Pan Head Cap	4	151052

## MANTA II PARTS LIST(cont...)

GB14	Foot, Rubber	4	154496
GB15	Screw, 1/4-20 X 3/4 Flat Head Phillips Cap	4	154657
GB16	Nut, 1/4-20 Hex	4	151893
H	Assembly, Handle, Slip	1	n/a
H1	Hub, Slip Handle	1	157321
H2	Spoke, Slip Handle	1	157322
H3	Knob, Ball 1/2-20 Female	2	154486
H4	Screw, 1/4-20 X 3/4 Thumb	1	157432
H5	Screw, 1/4-20 X 1/4 Socket Head Set	2	157528
K	Assembly, Accessory Pack (not shown)	1	n/a
K1	Carton, Accessory Pack	1	157323
K2	Owner's Manual, MK-Manta 2 Series Core Drill	1	
K3	Card, Warranty	1	155859
K4	MK Sell Sheet	1	155333
LA	Assembly, Motor, Milwaukee 4094	1	n/a
LA1	Motor, Milwaukee 4094, Shear Pin, 20A/120V	1	154633
LB	Assembly, Motor, Milwaukee 4096	1	n/a
LB1	Motor, Milwaukee 4096, Slip Clutch, 20A/120V	1	155540
LD	Assembly, Motor, Milwaukee 4004	1	n/a
LD1	Motor, Milwaukee 4004, Slip Clutch, 20A/120V	1	159263
LE	Assembly, Motor, Milwaukee 4097-20	1	n/a
LE1	Motor, Milwaukee 4097-20, Slip Clutch, 15A/120V	1	159264
LF	Assembly, Motor, Milwaukee 4090	1	n/a
LF1	Motor, Milwaukee 4090, Shear Pin, 15A/120V	1	155976
LJ	Assembly, Motor, Eibenstock EBM 300/3 P	1	n/a
LJ1	Motor, Eibenstock EBM 300/3/P, Slip Clutch, 20A/120V	1	158754
M	Assembly, 3/4" Motor Mount Plate, Hybrid, Milwaukee	1	n/a
M1	Motor Mount Plate, Hybrid	1	158412
M2	Screw, 3/8-16 x 1 1/4, Socket Hd. Cap	4	157529
M3	Key, 3/8 x 3/8 x 5	1	157520
M4	Screw, 1/4-20 x 1.0, Socket Hd. Cap	4	151049
MA	Assembly, 3/4" Motor Mount Plate, Hybrid, CB748	1	n/a
MA1	Motor Mount Plate, Hybrid	1	158412
MA2	Screw, 3/8-16 x 1 1/4, Socket Hd. Cap	4	157529
MA3	Key, 3/8 x 3/8 x 5	1	157520
MA4	Screw, 1/4-28 x 1.5, Socket Hd. Cap	4	154684
MB	Assembly, 3/4" Motor Mount Plate, Hybrid, Ebinstock	1	n/a
MB1	Motor Mount Plate, Hybrid	1	158412
MB2	Screw, 3/8-16 x 1 1/4, Socket Hd. Cap	4	157529
MB3	Key, 3/8 x 3/8 x 5	1	157520
MB4	Screw, M8 x 1.25 x 25mm, Socket Hd. Cap	4	157530
	Optional Accessories:		
N	Assembly, 2", Spacer Block Milwaukee	1	n/a
N	Spacer Block, 2" Milwaukee	1	154721
N2	Screw, 3/8-16 x 3 1/4, Socket Hd. Cap	4	161118
N3	Key, 3/8 x 3/8 x 5	1	157520

## HOW TO ORDER REPAIR PARTS

PLEASE HAVE THE FOLLOWING INFORMATION READY BEFORE CALLING:

SERIAL NUMBER OF YOUR SAW  
MODEL NUMBER OF SAW  
WHERE PURCHASED AND WHEN  
PART NUMBER  
PART DESCRIPTION

ALL PARTS LISTED MAY BE ORDERED FROM YOUR LOCAL DISTRIBUTOR OR FROM MK DIAMOND. IF THE PART IS NOT STOCKED LOCALLY, CALL OUR TOLL FREE NUMBER LISTED BELOW AND ASK FOR OUR CUSTOMER SERVICE DEPARTMENT. FOR TECHNICAL SUPPORT CALL: 1 (800) 474-5594. THERE IS A \$25.00 MINIMUM ORDER.

## RETURNED MERCHANDISE POLICY

SHOULD YOU NEED TO RETURN ANY PRODUCT YOU HAVE PURCHASED FROM MK DIAMOND, PLEASE OBSERVE THE FOLLOWING:

OUR CUSTOMER SERVICE DEPARTMENT SHOULD BE CONTACTED FOR APPROVAL TO RETURN MERCHANDISE. MERCHANDISE WILL NOT BE ACCEPTED WITHOUT A RETURNED GOODS AUTHORIZATION NUMBER. ALL RETURNED MERCHANDISE MUST BE SHIPPED PREPAID TO DESTINATION. ALL RETURNED MERCHANDISE MUST HAVE BEEN PURCHASED WITHIN THE PREVIOUS 12 MONTHS AND BE IN RESALABLE CONDITION. A RESTOCKING CHARGE OF 15% WILL BE BILLED.

## PARA ORDENAR PARTES DE REPUESTO

SÍRVASE TENER LISTA LA SIGUIENTE INFORMACIÓN ANTES DE LLAMAR:

NÚMERO DE SERIE DE LA SIERRA  
NÚMERO DE MODELO DE LA SIERRA  
DÓNDE Y CUANDO SE COMPRÓ LA SIERRA  
NÚMERO DE LA PARTE  
DESCRIPCIÓN DE LA PARTE

TODAS LAS PARTES LISTADAS SE PUEDEN PEDIR A TRAVÉS DE SU DISTRIBUIDOR AUTORIZADO O DIRECTAMENTE A MK DIAMOND. SI LA PARTE NO ESTÁ EN EXISTENCIA LOCAL, LLAME AL NÚMERO DE TELÉFONO INDICADO ABAJO Y PIDA EL DEPARTAMENTO DE ATENCIÓN AL CLIENTE. PARA SOPORTE TÉCNICO, LLAME AL 1-800-474-5594 SIN CARGO. EL PEDIDO MÍNIMO ES DE \$25.00.

## POLÍTICA DE DEVOLUCIÓN DE MERCANCÍA

EN CASO DE QUE SEA NECESARIO DEVOLVER ALGÚN PRODUCTO QUE USTED HAYA COMPRADO A MK DIAMOND, SÍRVASE OBSERVAR LO SIGUIENTE:

USTED DEBE DIRIGIRSE A NUESTRO DEPARTAMENTO DE ATENCIÓN AL CLIENTE PARA RECIBIR UNA APROBACIÓN DE DEVOLUCIÓN DE MERCANCÍA. NO SE ACEPTARÁ MERCANCÍA DEVUELTA SIN EL CORRESPONDIENTE NÚMERO DE PAGADO HASTA SU DESTINO. TODA LA MERCANCÍA DEVUELTA DEBERÁ EMBARCARSE CON FLETE MESES ANTERIORES Y ESTAR EN CONDICIONES DE PODERSE VENDER COMO NUEVA. SE APLICARÁ UN CARGO DE 15% POR REINTEGRO AL ALMACÉN.

## POUR COMMANDER LES PIÈCES DE RECHANGE

VEUILLEZ AVOIR LES INFORMATIONS SUIVANTES AVANT D'APPELER :

NUMÉRO DE SÉRIE DE LA SCIE  
NUMÉRO DE MODÈLE DE LA SCIE  
DATE ET LIEU D'ACHAT  
RÉFÉRENCE  
DESIGNATION DE LA PIÈCE

TOUTES LES PIÈCES INDIQUÉES PEUVENT ÊTRE COMMANDÉES AUPRÈS DE VOTRE DISTRIBUTEUR LOCAL OU AUPRÈS DE MK DIAMOND. SI LA PIÈCE N'EST PAS STOCKÉE LOCALEMENT, VEUILLEZ APPELER NOTRE NUMÉRO D'APPEL GRATUIT INDIQUÉ CI-DESSOUS ET DEMANDER LE SERVICE DE LA CLIENTÈLE. POUR SUPPORT TECHNIQUE, VEUILLEZ CONTACTER LE 1 (800) 474-5594. UN MINIMUM DE COMMANDE 25,00 DOLLARS US EST DE RIGUEUR.

## POLITIQUE DE RETOUR DE MARCHANDISES

SI VOUS VOUS TROUVEZ DANS L'OBLIGATION DE RETOURNER UN PRODUIT DONT VOUS AVEZ FAIT L'ACHAT À MK DIAMOND, VEUILLEZ SUIVRE LES CONSIGNES SUIVANTES:

NOTRE SERVICE DE CLIENTÈLE DEVRAIT ÊTRE CONSULTÉ POUR APPROBATION AVANT DE RETOURNER TOUTE MARCHANDISE. LA MARCHANDISE NE SERA EN AUCUN CAS ACCEPTÉE SANS NUMÉRO D'AUTORISATION DE MARCHANDISES RETOURNÉES. TOUTES LES MARCHANDISES RETOURNÉES DOIVENT AVOIR FAIT L'OBJET DE L'ACHAT DANS LES 12 MOIS PRÉCÉDENTS ET ÊTRE EN ÉTAT DE REVENTE. UNE CHARGE DE RESTOCKAGE DE 15% SERA FACTURÉE.



MK Diamond Products, Inc.

1315 Storm Parkway. Torrance, CA 90509-2803  
1 (800) 421-5830 FAX 1 (310) 539-5158

Manual Part No. 161116  
Revision 03/05