



# Model MK 880 1 H.P. Tile Saw Owner's Manual Parts List and Operating Instructions



## Serial Number \_\_\_\_\_

You should record the serial number of your saw on this owner's manual and on the warranty card, which must be sent in to be effective. Be sure to include all pertinent information required.



**Caution: Read safety and general instructions carefully before using saw for the first time.**

# Table of Contents

	Page		Page
Symbols/Definitions.....	1	Pan Removal.....	7
General Safety Instructions.....	2	Securing Table .....	7
Warranty Information.....	3	Maintenance.....	7
Features .....	3	Adjustments .....	8
Unpacking and Preparation.....	3	Belt Tightening/Replacement .....	8
Installing Blade and Cutting Head.....	4	Thermal Overload Switch.....	8
Installing Water Pump.....	4	Depth of Cut.....	8
Motor Specification .....	4	Accessories .....	9
Electrical Requirements .....	4	Stand Safety Instructions .....	9
Wiring Diagram .....	5	Parts Listing .....	10
Selecting a Generator.....	5	Exploded View .....	11
Cord Requirements .....	5	Do's/Don'ts .....	12
Operations:		Cutting Speed/Depth.....	12
Rip Cutting & 45° Cutting.....	6	Trouble Shooting .....	12
2-Position Cutting Head.....	6	Service Centers: .....	13
Table Markings .....	6	Returned Merchandise Policy.....	Back Cover

## Symbols/Definitions



WARNING ELECTRICAL HAZARD



WARNING, DANGER, CAUTION



READ OWNER'S MANUAL



WEAR HEARING PROTECTION WHEN OPERATING EQUIPMENT



WEAR EYE PROTECTION WHEN OPERATING EQUIPMENT



WEAR HEAD PROTECTION WHEN OPERATING EQUIPMENT



ALWAYS OPERATE UNIT WITH BLADE GUARD IN PLACE

# General Safety Instructions for Tile Saws

**Safety is a combination of operator common sense and alertness at all times when the saw is being used.**

**WARNING: For your own safety and protection, do not attempt to operate saw until it is completely assembled and installed according to the instructions... And until you read and understand the general safety instructions.**

- Take time to read and understand fully the owner's manual and instructions and all safety/caution labels attached to the saw.
- All saws are equipped with UL approved 3-pronged electrical cord and plug or the appropriate international plug. Do not remove or use in a 2-prong receptacle.
- Keep blade guard in place at all times.
- Keep work area clean and safe.
- Be sure you have the right saw and blade for the work to be done. Forcing a tool to do a job for which it was not designed invites hazardous results and failure.
- Use safety goggles to comply with ANSI Z87.1 as well as wear dust mask and ear plugs for protection.
- Maintain all tools with care for the safest and best performance.
- Always make sure switch is "OFF" before plugging unit into electrical power.
- Never leave saw running unattended. Turn power off.
- Never stand on saw or use saw on an unsupported surface.
- Be sure the saw is secure and stable before cutting
- Protect your Eyes, Hands, Face, Ears and Body with the proper clothing and safety equipment.
- Do not attempt to cut pieces too small to hold by hand outside the blade guard.
- Avoid awkward hand positions where a sudden slip could cause a hand to move into the blade.
- When cutting a large piece of material, make sure it is fully supported at cutting height.
- Hold workpiece firmly against cutting table.
- Only feed the material fast enough for blade to cut. **DO NOT FORCE.**
- Always disconnect motor electrical cord from power source before cleaning, changing blade or any servicing.
- Should any part of this saw be missing or damaged or any electrical component fail to perform properly, shut off power and unplug from power source. Replace damaged, missing, and/or failed part before resuming operation.
- Always keep alert. Do not allow familiarity (gained from frequent use) to cause a careless mistake. Always remember that a careless fraction of a second is sufficient to inflict severe injury.

**THINK SAFETY** The operation of any power tool can result in foreign objects being thrown into the eyes causing severe damage. Use safety goggles to comply with ANSI Z87.1



**FORESIGHT IS BETTER THAN NO SIGHT**

## Warranty Information

If, within one (1) year from the date of purchase, this MK Diamond saw fails due to a defect in material or workmanship, MK will repair it, free of charge, by returning the unit to the dealer where it was purchased. This warranty DOES NOT cover normal wear or damage resulting from operator abuse. In no event shall MK Diamond Products, Inc. be liable for consequential damages arising out of the failure of any product. Selected components such as motors/engines are excluded from this warranty and are subject to the manufacturer's warranty. Each manufacturer carries its own warranty conditions which are listed on the literature accompanying the motor/engine at the time of purchase. MK Diamond Products may act as a warranty station for the motors/engine repairs based on individual agreement with the manufacturer. This warranty is in lieu of all other warranties expressed or implied.

## Saw Features

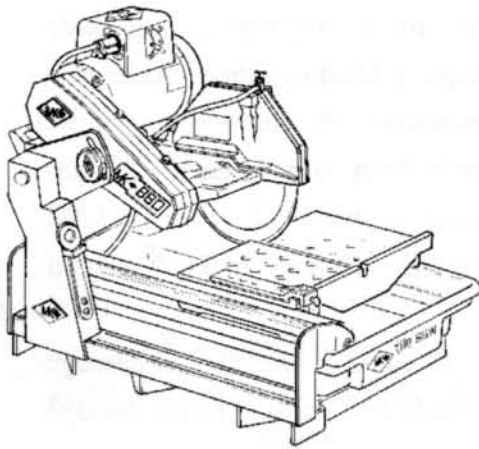

- Two position cutting head
- Portable 87 lbs.
- Durable high torque 1 h.p. motor
- Rips tile and marble to 16" x 16"
- Blade guard is hinged for safe and easy blade changes
- Includes miter fixture, rip guide, water pump, bullnose adaptor & side table extension
- Sealed heavy-duty blade shaft bearings are permanently lubricated.
- Linear slide bar and cover offer precision and maintenance free operation

## Unpacking, Assembly and Preparation

Carefully open carton. Remove saw and separate all parts from the packing material. Check each item with illustration making certain all items are accounted for and in good condition before discarding any packing material. If there are any missing or damaged parts, call our toll free number 1-(800) 421-5830 for instructions before proceeding with the assembly.

Contents of carton:

saw	owner's manual
blade	warranty card
water pump	drain plug
pump adaptor	wrench
pump hose	plastic pan
45° miter fixture	rip guide

**⚠ WARNING:** For your own safety, never connect plug to power source outlet until all assembly steps are complete. Read and understand the safety and operational instructions. Lift the saw by the frame and place onto level work surface or optional stand ....See stand assembly instructions.

Familiarize yourself with the controls and features of this saw shown in the illustration on page 3. (Descriptions and illustrations are as accurate as possible at the time of publication. Illustrations may include optional equipment or accessories and may not show all models covered by this literature.)

## Installing the Blade and Cutting Head

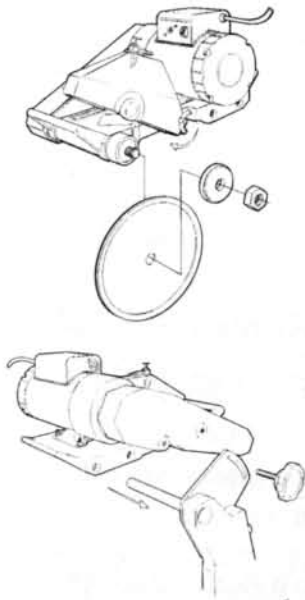

Attach blade guard to the cutting head, raise blade guard to it's highest position and tighten wing nut. Remove the blade shaft nut and the outer flange. Place blade onto the shaft making sure arrows point down (direction of rotation). Reinstall the outer flange and the blade shaft nut. Use wrench to secure the nut. Be careful not to over-tighten! Lower blade guard and retighten wing nut. Assemble cutting head to frame. After cutting head is installed, check to see that the blade tracks in the center of the conveyor cart. The cart should move freely from front to back. Loosen the adjustment knob and adjust cutting head so that blade rim is at least 1/4" below the top surface of the conveyor cart. Tighten the knob to hold cutting head in place.

**CAUTION:** Setting the blade too high will cause it to grab and damage the tile and possibly the saw. Setting the blade too low will cause damage to the conveyor cart.

## Installing Water Pump

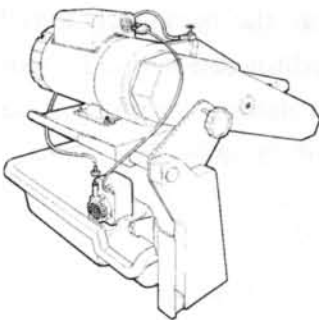

Unpack and inspect the pump from it's carton to insure that no damage has occurred in shipping. Attach the nipple to the pump outlet and connect plastic tubing to outlet and valve fitting on blade guard. Connect the pump plug to receptacle on cutting head. Place the pump in the water pan cradle. The water pump has sealed bearings and is thermally protected. Water level should be above pump intake level to ensure proper operation. Cold weather and low voltage may cause pump not to function properly. Be sure that pump is clear of sediment before operation.

**CAUTION:** Disconnect and remove water pump when cutting dry.

## Motor Specifications and Electrical Requirements

• Horsepower	1 , saw duty	• Hertz	60
• Volts	120/230	• Phase	1
• Amperes	16 - 12	• Class	F
• R.P.M.	1725		

## Wiring Diagram

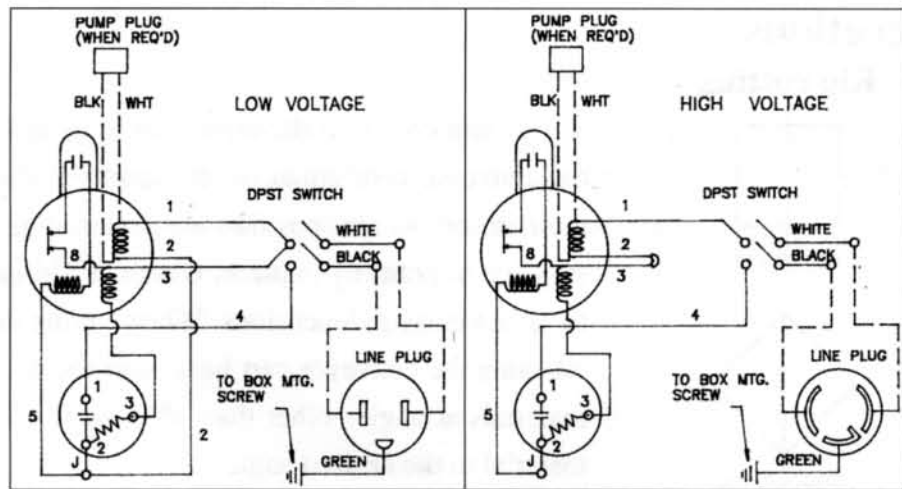

## Selecting A Generator

A fundamental problem in selecting an engine-driven generator is to determine the power (kilowatt) requirements which must be met under operating conditions.

Undersizing of the equipment can be avoided by considering all of the loads that will be connected to the generator, and by determining the starting requirements (motor start) of electric motor operated devices. Be sure the generator you select is large enough to handle your present requirements and anticipated needs.

To determine the right size generator, add the total watts of all lights, appliances, tools or other equipment to be connected to the generator.

Check the nameplates to determine wattage. If wattage is not shown, but amps and volts are given, the following simplified formula may be used:

Amps x Volts = Watts x Startup Surge = Total Watts as K.W. required to start and run motor.

Example: 12.5 Amps x 120 Volts = 1500 Watts

1500 Total running watts x 5 startup surge = 7,500 watts or 7.5 KW required. (1KW = 1000 watts).

## Cord Requirements

Before connecting saw to power supply, check that the voltage and phase on motor are the same as power supply. The electrical circuit should be 110 volts AC, 60 Hertz, 20 amps; protected by 20 amp breaker. **Power supply must be grounded using three conductor extension cords with three prong ground plugs and receptacles.**

Using the following as a guide:

WIRE GAUGE:	#14	#12	#10
110 VOLTS:	25'	50'	75'

Use only UL listed cords and connect saw as close to power source as possible.

# Operations

## Rip cutting

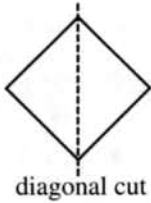
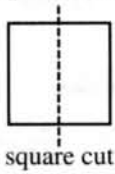

Rip cutting is the term used to describe cutting the material flat on the conveyor cart, either on the square or the diagonal. When cutting the material on square, position the material against the conveyor cart back stop and hold firmly in place. Use the rip guide for positioning the material for exact cutting dimensions. When cutting diagonally, position the material using the conveyor cart back stop and the dual 45° fixture. For cutting materials at angles other than 45°, use the 0 - 90° protractor to align the material to the desired angle.

## 45° Cutting

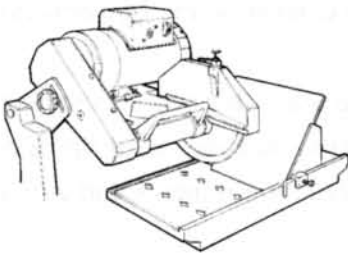

45° miter cutting is the term used to describe cutting the end of the material to a 45° bevel. Position the material against the 45° miter plate with the edge to be cut resting on the conveyor cart. Hold the material firmly against the miter plate and push the material completely through the blade.

## 2- Position Cutting Head

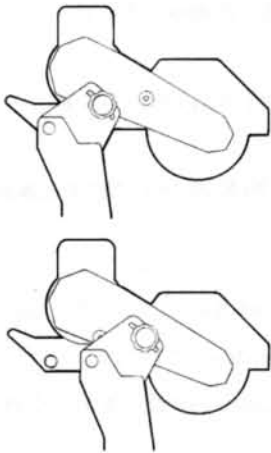

The cutting head is installed on the pivot shaft using one of two sets of holes selected by the saw operator depending on the material to be cut. The pivot hole closest to the blade is used to cut material up to 12" in size. The hole farthest from the blade is used for materials up to 16" in size.



**NOTE:** When changing the position of the cutting head on the pivot shaft, make sure the shaft is properly lubricated with "Lubriplate" grease.

## Table Markings Explanation

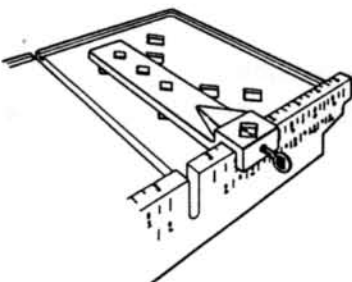

The markings on the conveyor cart backstop are used for precision cutting to exact dimensions. The scale on the top of the backstop is used for setting the rip guide alignment indicator to the desired dimension. The scale on the front face of the backstop is used to indicate the *actual* position of the material being cut. This offset takes into account the width between the rip guide indicator and the rip guide edge surface.

## Removal of Pan

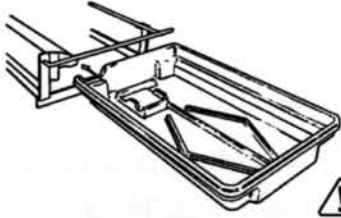

The water pan is removed by sliding the pan straight out through the front of the saw frame. When reinstalling the pan, make sure that the lip of the pan is aligned with the notches in the frame brackets and the bottom of the pan rests securely on the frame cross bars.

 **NOTE:** Clean the pan after every use.

## Securing table

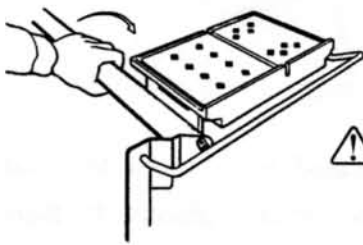



The conveyor cart may be secured into position for transportation and storage. Rotate the linear bearing guide bar cover in a clockwise direction until the conveyor cart is tight. To release, rotate the conveyor table in a counter clockwise direction until the cart moves freely.

 **NOTE:** This is not a locking device. The conveyor cart may move during transportation.

## Maintenance

**Failure to maintain saw in accordance with the manufacturer's recommendations may void the warranty.** Cleaning the saw after every use will ensure long life and trouble-free cutting. Raise conveyor cart to clean linear bearing and guide bar. Lubricate guide periodically with a light machine oil. Wipe off the cutting head and other surfaces.

 **WARNING:** For your safety, turn switch off and remove plug from power source outlet before maintaining or cleaning your saw. If the power cord is damaged in any way from wear or cuts, replace it immediately.

 **DO NOT** service the motor's internal parts yourself. Call MK Diamond's customer service department at 1-800-421-5830 for help in solving any problems.

 **DO NOT** attempt to square or level the conveyor cart as this is preset at the factory.



# Adjustments

## Belt Tightening/Replacement

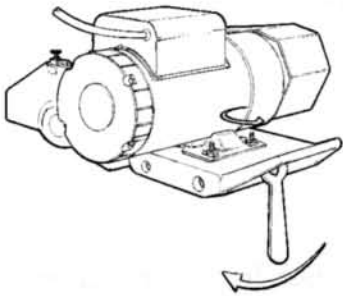

For proper operation, drive belt must be properly adjusted and in good condition. Replace the belt if worn, cracked or frayed. To adjust the belt, loosen the motor mounting nuts and adjust the motor strap tension. After adjusting the belt, be sure to retighten the motor mounting nuts.



**WARNING:** Always unplug the motor prior to performing any maintenance or cleaning task.

## Thermal Overload Switch

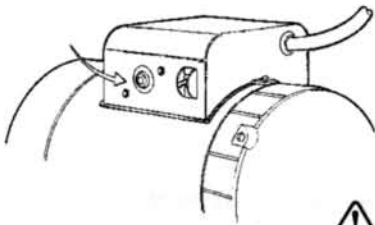

The thermal overload reset switch is located on the motor terminal cover and trips when the motor overheats. If the motor overheats, the thermal protection will cause the motor to shut off. If this should occur, allow approximately 10 minutes for the motor to cool down, then push the switch to reset.



**NOTE:** If saw continues to shut off, check for low voltage, voltage drop, or too long of an extension cord.

## Depth of Cut

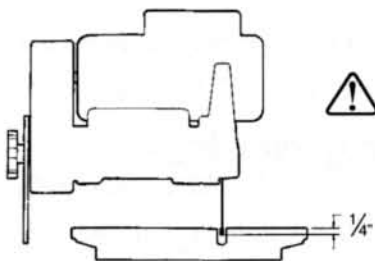

When cutting through material, the blade should penetrate at least 1/4" (6.35mm) below the surface of the conveyor cart. This adjustment is made by loosening the adjustment knob and raising or lowering the cutting head.

**CAUTION:** Setting the blade too low may cause damage to the conveyor cart. If the blade is too high, it may cause the blade to bind in the material being cut.

## Optional Accessories



**Dual 45° Flat Angle Guide** - used to align the material for flat diagonal 45° cutting. P/N 133025



**90° Protractor** - used to align the material for cutting any desired angle. P/N 134569



**Folding Stand** - Sturdy steel stands allow operator to have work surface at a standing height. P/N 151889

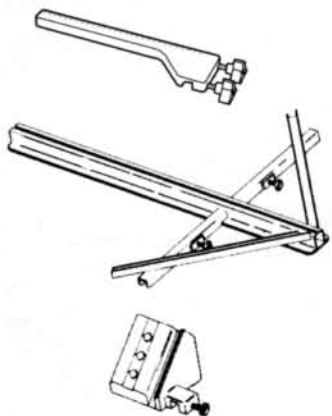

**Extended Rip Guide** - Sturdy steel guide allow operator to align larger materials for cutting. P/N 154014

**18" Diagonal Cutting Kit** - Sturdy steel guide allows operator to align larger materials for diagonal cuts. P/N 137356

**Small Bullnose Miter** - Sturdy steel fixture used to align materials for 45° mitering. P/N 153201

## Optional Stand Safety Instructions



When setting the saw on the stand, be sure the saw frame seats firmly in the stand brackets. The "point" of the V-strut should fit over the small V-shaped stand bracket, and the strut opposite the point should fit over the large V-shaped stand bracket.



**CAUTION:** Always set the stand on a firm, level surface to prevent tipping or sliding.

## Parts Listing: MK-880

ITEM	DESCRIPTION	PART NO.
1	Motor, 1 HP 110VAC 1725 RPM 60 Hz, without pulley .....	152599
2	Water Pump Receptacle .....	150576
3	Toggle Switch, 1 HP motor .....	135798
4	Thermal Overload Switch - 1h.p. ....	153503
5	Splash Curtain .....	134841
6	Water Valve .....	152695
7	Water Hose (2 ft. required).....	132951
8	Blade Guard .....	152666
9	Blade Shaft Nut .....	135848
10	Outer Flange.....	135830
11	Blade - 8" MK-200.....	137158
12	Inner Flange .....	137737
13	Bearings (2 required).....	137711
14	Water Pump Adaptor .....	128397
15	Water Pump .....	151271-MK
16	Frame.....	153728
17	Plastic Pan .....	153352
18	Drain Plug .....	153439
19	Side Table.....	154073
20	Roller Wheel (nylon).....	151799
21	Roller Wheel Mounting Bracket .....	151800
22	Conveyor Cart .....	153438
23	Rip Guide .....	134551-MK
24	Linear Bearing Bushings (2 required).....	151781
25	Linear Bearing Mount .....	152725
26	Guide Bar .....	153361
27	Guide Bar Cover .....	153321
28	Blade Shaft Wrench.....	134684
29	Post.....	153517
30	Adjustment Knob .....	137786
31	Blade Shaft .....	137729
32	Inner Belt Guard Bracket .....	153260
33	Blade Shaft Pulley .....	134676
34	Belt Guard .....	152669
35	V-Belt AX-25 .....	152403
36	Motor Pulley.....	152628
37	2 Position Cutting Head with Shaft & Bearings .....	152719
38	Motor Adjustment Strap.....	152673
Optional Items - Not Shown		
	Drain Plug - 2 pack .....	133025-MK
	Dual 45° Fixture .....	134577-MK
	0-90° Protractor .....	134569-MK
	45° Bullnose Miter Plate - small .....	134585-MK
	Folding Stand .....	151889
	45° Bullnose Miter Fixture - large .....	153201

# Exploded View -

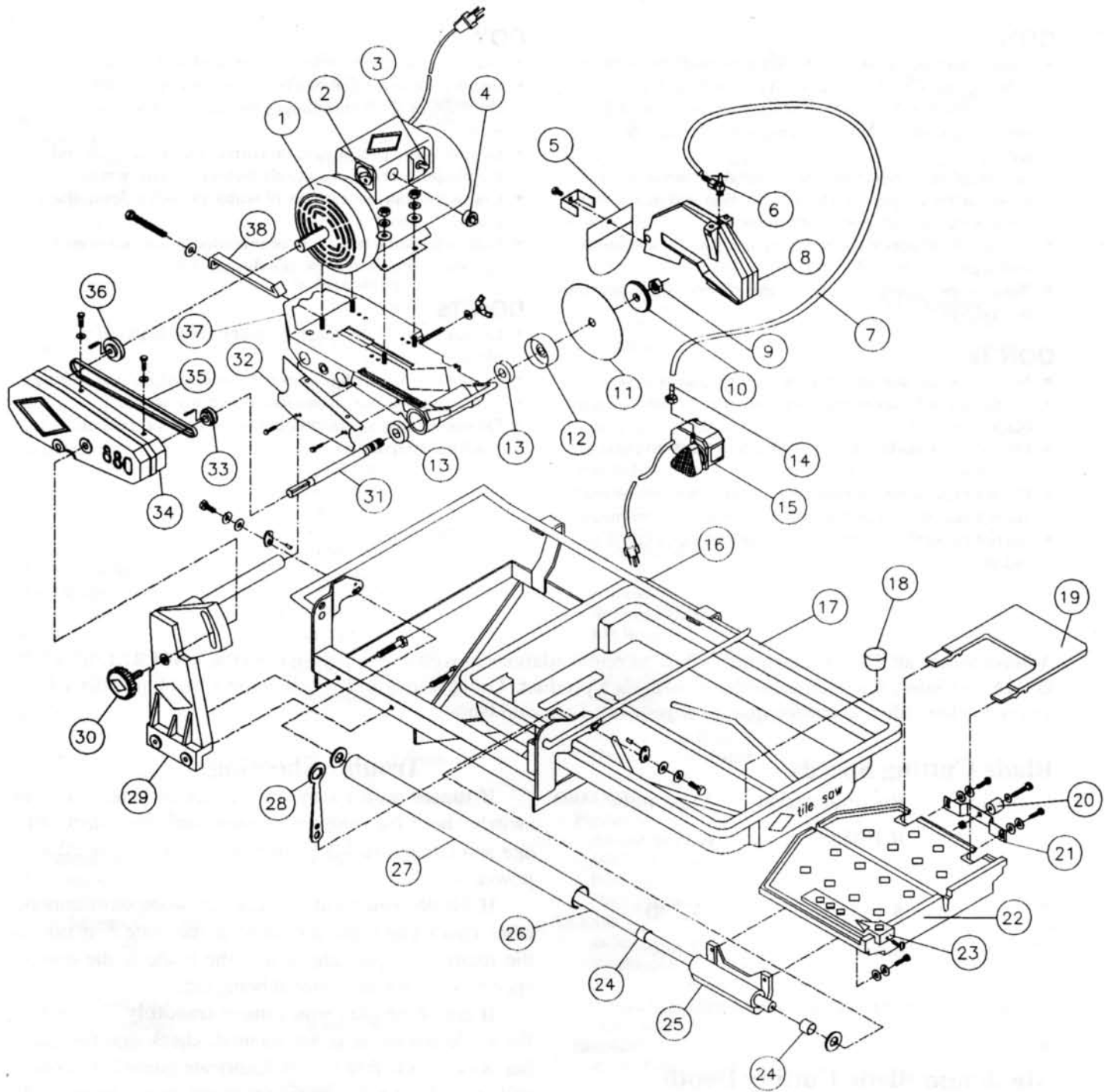

# Do's/Don'ts

Inspect all blades daily for any damage before mounting.

## Dry Cutting Blades

### DO's

- Follow manufacturer's blade recommendation for material being cut. Check for suitability of cutting dry.
- Inspect diamond blade for damage before mounting on saw. Check arbor shaft and flanges for damage or uneven wear.
- Be sure blade is mounted on correct diameter shaft with arrow in the proper direction of rotation and blade shaft nut is securely tightened with wrench.
- Inspect blade periodically during use for fatigue cracks and segment damage.
- Wear proper safety equipment and observe safe operating procedures.

### DON'Ts

- Never operate any saw without safety guards in place.
- Do not exceed maximum operating speed established for blade diameter.
- Do not force blade into material: allow blade to cut at its own speed.
- Do not make long continuous cuts with dry cutting blades: allow blade to cool by turning in air every few minutes.
- Do not cut or grind with side of blade or cut a curve or radius.

## Wet Cutting Blades

### DO's

- Match blade specification with material to be cut.
- Inspect blade for damage before mounting on saw: check arbor shaft and flanges for damage and uneven wear.
- Be sure blade is mounted on correct diameter shaft and the blade shaft nut is securely tightened with wrench.
- Check for continuous flow of water to both sides of the blade.
- Follow manufacturer's recommended pulley sizes and operating speeds for specific diameter blades.

### DON'Ts

- Do not operate any machine without blade guard in place.
- Do not cut dry with blades recommended for wet cutting.
- Do not exceed maximum safe operating speed.
- Do not operate saw with blade diameter larger than machine's capacity.

Always follow all the manufacturer's safety recommendations as well as complying with the ANSI B7.1, B7.5, OSHA and Safety Guidelines furnished with each product. Using blades and machines in a SAFE manner will assure the long life and cutting quality of your MK Diamond blades.

## Blade Cutting Speeds

Diameter	Recommended R.P.M.s*	Maximum R.P.M.s
7"	5,184	8,730
8"	4,536	7,640

\* Based on 9,500 SFPM optimum performance range + or - 10%.

## Maximum Blade Cutting Depth

8" 2-3/4" depth

Note: Cutting depths are approximate and will vary with different blades and saws

## Trouble Shooting

**If motor won't stay on** - check thermal overload switch, check for correct extension cord size, check voltage and circuit breaker from power source. Use 20 amp power.

**If blade won't cut** - check for worn out diamond edge, check that blade is rotating in the same direction as the rotation arrows, check that the blade is the correct specification for the material being cut.

**If conveyor cart won't move smoothly** - check that the guide bar cover is not secured, check that the guide bar is clean and free of dirt. Lubricate guide bar periodically with light machine oil per maintenance instructions on page 7.

**If water won't flow evenly to both sides of the blade** - check that the water line is clear of dirt, check that the water jets in the blade guard are clear, check that the pump filter is not clogged.

## HOW TO ORDER REPAIR PARTS

Always have the following information ready before calling:

**Serial number of your saw**

**Model number of saw**

**Where purchased and when**

**Part description**

**Part number**

All parts listed may be ordered from your local distributor or from MK Diamond. If the part is not stocked locally, call our toll free number listed below and ask for our customer service department. There is a \$ 25.00 minimum order.

### Returned Merchandise Policy

Should you need to return any product you have purchased from MK Diamond, please observe the following:

Our customer service department must be contacted for approval to return merchandise: **MERCHANDISE WILL NOT BE ACCEPTED WITHOUT A RETURNED GOODS AUTHORIZATION NUMBER.** All returned merchandise must be shipped prepaid to destination.

All returned merchandise must have been purchased within the previous 12 months and be in resalable condition. A restocking charge of 15% will be billed.



MK DIAMOND PRODUCTS, INC.  
1315 Storm Parkway  
Torrance, CA 90509-2803  
1 (800) 421-5830 FAX 1 (310) 539-5158